

Technical data

Positioned between the bell-housing motor flange and lid of the tank, they help to reduce the transmission of the vibrations and emission of noise generated by the system.

Damping rings provide a perfect hydraulic sealing actions by virtue of their special profile; damping rings are available for IEC electric motors from size 80 to size 315.

Compatibility with fluids

- Mineral oils types HH-HL-HM-HR-HV, to ISO 6743/4 standard
- Water based emulsions types HFAE-HFAS, to ISO 6743/4 standard

Materials

Internal ring: pressure die-cast aluminium alloy
External body: NBR 75 Shore A

Temperature

From -30 °C to +80 °C

Special Applications

Any applications not covered by the normal indications contained in this catalogue must be evaluated and approved by MP Filtri Technical and Sales Department

Example of assembly

In order to warranty the application, to proceed with the calculation of the max weight and moment with the following formulas.

Values higher than those in the table could damage the product and couldn't warranty the conformity of the application!

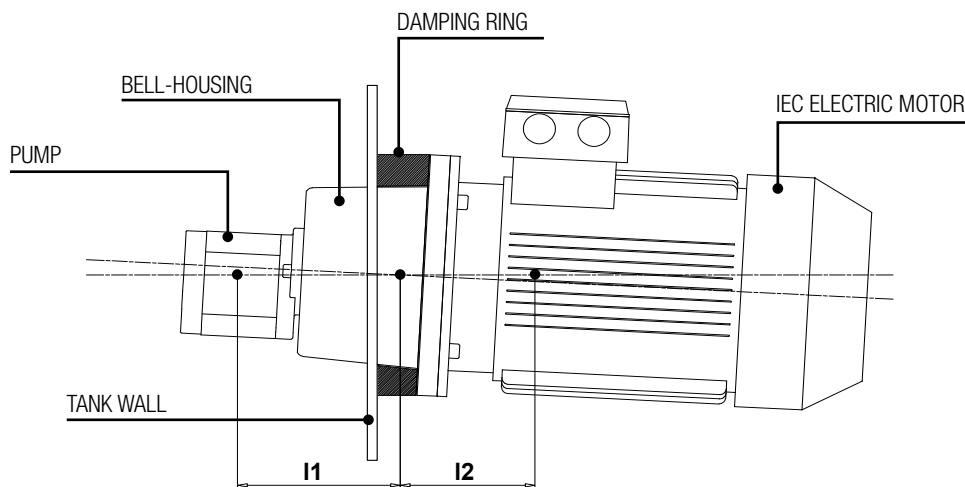

$$F_{perm} \geq F_p + F_m$$

$$M_b perm \geq F_m \times l_1 - F_p \times l_2$$

Permissible radial weight and bending load for damping rings

Code	F perm [N]	Mb perm [N·m]
ANM A 200	370	30
ANM A 250	720	65
ANM A 300	1450	175
ANM A 350	3600	740
ANM A 400	4800	1100
ANM A 450	6600	1600
ANM A 550	13000	4400
ANM A 660	24000	9000

Legend of symbol

- F perm** = ammissible load (N)
- Fp** = pumps weight (N)
- Fm** = motor weight (N)
- Mb perm** = bending load (N·m)

ANM A 200 ÷ 400

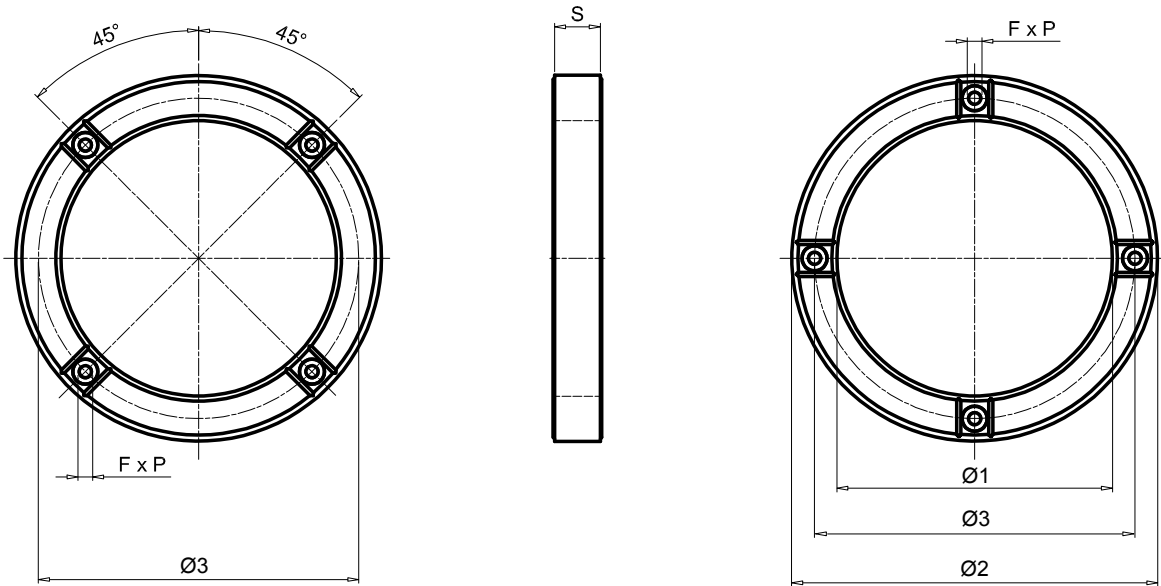

Code	IEC - Electric motors	Dimensions [mm]					Nr. F	Screw tightening torque [N·m]	Weight [kg]
		Ø1	Ø2	Ø3	S	F x P			
ANM A 200	80, 90S / 90L	144	200	165	40	M10x16	4+4	23	1.70
ANM A 250	100L / 112M	191	250	215	45	M12x16		40	2.53
ANM A 300	132S / 132M	238	300	265	50	M12x16		40	2.15
ANM A 350	160L/160M, 180L/180M	260	350	300	58	M16x20		100	3.95
ANM A 400	200L	301	400	350	50	M16x25		100	4.60

ANM A 450 ÷ 660

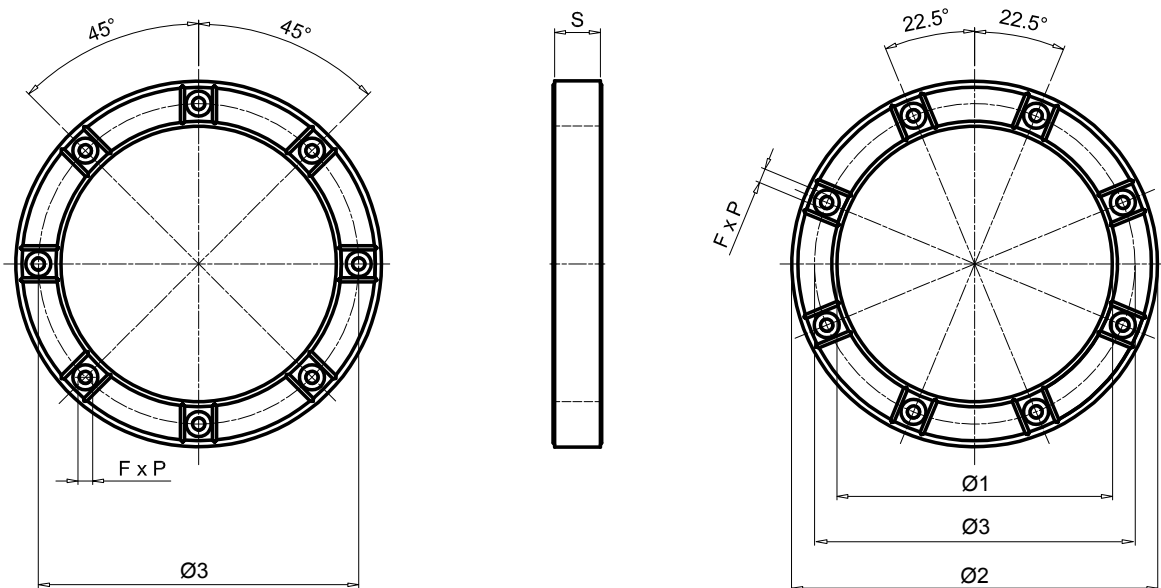

Code	IEC - Electric motors	Dimensions [mm]					Nr. F	Screw tightening torque [N·m]	Weight [kg]
		Ø1	Ø2	Ø3	S	F x P			
ANM A 450	225S / 225M	352	450	400	60	M16x25	8+8	100	6.20
ANM A 550	250M, 280M / 280S	452	550	500	60	M16x25		210	7.76
ANM A 660	315M / 315S	552	660	600	67	M20x25		410	11.25