

Technical data

Made of pressure die-cast aluminium alloy, these tanks feature superior strength and optimum design and are ideal for compact hydraulic power units.

Generously proportioned fins ensure efficient cooling.

The tank is supplied with:

- M6 threaded fixing holes for lid
- feet with M8 threaded fixing holes
- G 3/8" threaded drain hole

The lid is sealed by a gasket made of special paper, which must be ordered separately indicating code "GUS 10.0".

Dimensions

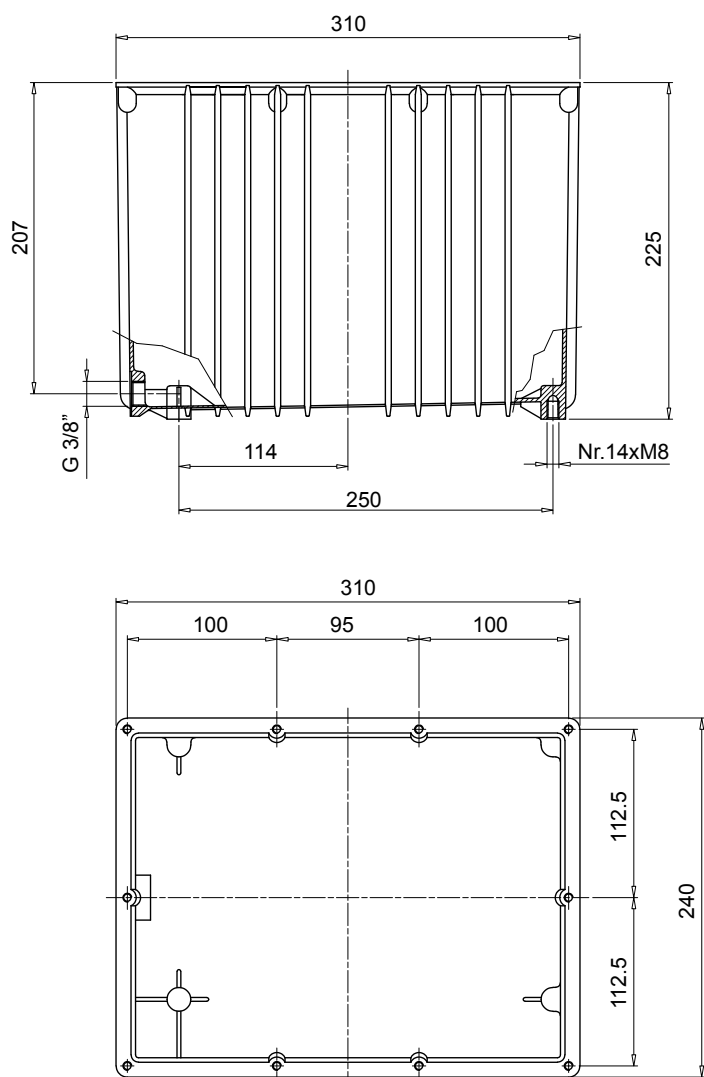

Code	Weight [kg]
SE10LT	4.0